



# M-WELD ONE EDGE FASCIA

BUILT-UP OR MODIFIED VERSION

## SPLICE PLATE VERSION INSTALLATION INSTRUCTIONS

### TYPICAL INSTALLATION FOR 12'-0" STRAIGHT COVER

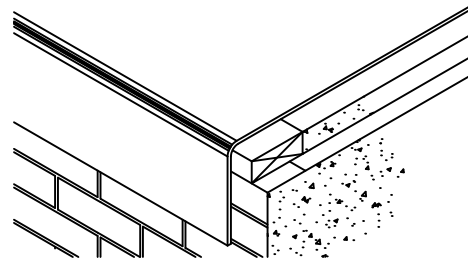
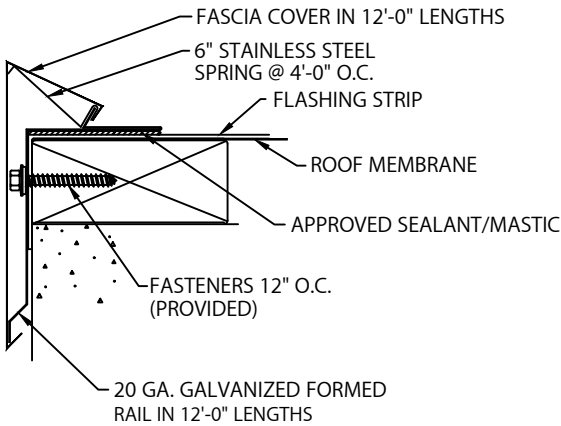

### STEP 1 - MEMBRANE

POSITION BASE SHEET OF THE BUILT-UP OR MODIFIED ROOFING MEMBRANE OVER THE ROOF EDGE COVERING NAILS COMPLETELY.

NOTE: FOLLOW GENERAL RECOMMENDATIONS OF THE ROOFING MANUFACTURERS APPLICATION OF THE MEMBRANE OVER THE EDGE.

CAUTION: TAKE EXTREME CARE TO AVOID SPILLAGE OF THE ASPHALT OVER THE EDGE

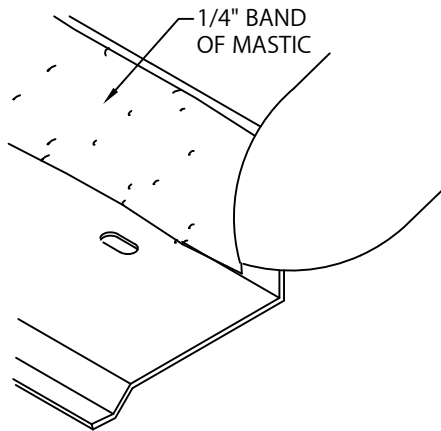

BASE RAIL SHOWN WITH INSIDE FACE UP.

### STEP 2 - BASE RAIL (PREPARATION)

LAY THE BASE RAIL ON THE DECK WITH THE OUTSIDE FACE DOWN. IF NECESSARY, CLEAN THE BACK SIDE OF THE BASE RAIL OF DUST OR DIRT. APPLY A HEAVY 1/4" BAND OF MASTIC /SEALANT TO THE BACK OF THE DECK FLANGE FOR THE ENTIRE LENGTH OF THE RAIL AS SHOWN

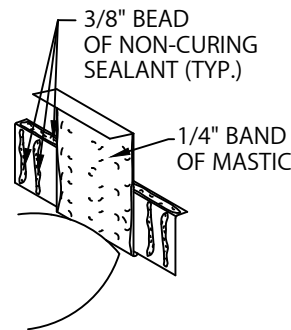

### STEP 3 - BASE RAIL SPLICE PLATE

APPLY A HEAVY 1/4" BAND OF APPROVED MASTIC/SEALANT TO THE BOTTOM OF THE 2" WIDE DECK FLANGE OF THE RAIL SPLICE PLATE AS SHOWN.

NEXT, APPLY 3/8" BEADS OF NON-CURING SEALANT TO TOP AND SIDES OF THE RAIL SPLICE AS SHOWN.

# GAF

1 CAMPUS DRIVE, PARSIPPANY, NJ 07054 USA  
973-628-3000  
WWW.GAF.COM

DATE: 03/31/22  
DRN BY: MLM  
CKD BY: MM

SHT.# 1 OF 4  
DWG# 25110-38071

A



# M-WELD ONE EDGE FASCIA

BUILT-UP OR MODIFIED VERSION

## SPLICE PLATE VERSION INSTALLATION INSTRUCTIONS

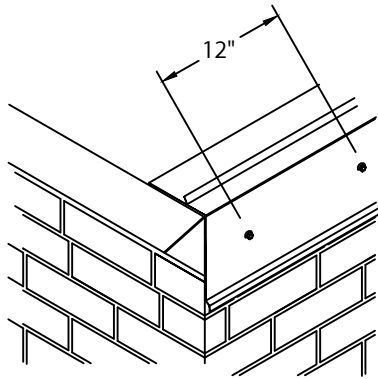

### STEP 4 - OUTSIDE MITERS

ON THE BUILDING CORNER, IDENTIFY THE "DOG EAR" OR THE OVERLAP OF THE FLASHING STRIP. FASTEN A 12'-0" SECTION OF BASE RAIL, PREPARED WITH MASTIC/SEALANT AS SHOWN IN STEP #2, TO THE OPPOSITE FACE, WITH THE END EVEN WITH THE EDGE OF THE WALL. FASTEN IN PLACE THROUGH THE RAIL SLOTS 12" O.C. WITH PROVIDED FASTENERS.

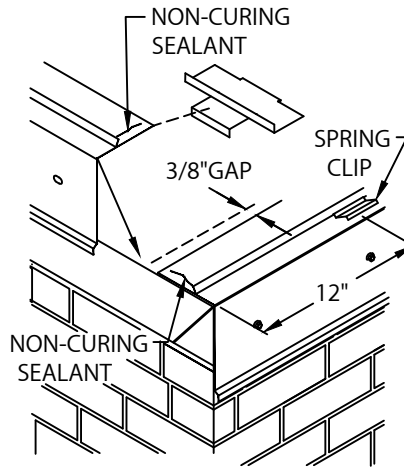

### STEP 5 - OUTSIDE MITERS

APPLY NON-CURING SEALANT ADJOINING ENDS OF BASE RAIL AS SHOWN. SLIDE BASE RAIL SPLICE PLATE OVER THE EDGE OF 12'-0" RAIL SECTION. INSTALL RAIL SECTION TO "DOG EAR" SIDE OF THE WALL, LEAVING A 3/8" GAP TO ADJOINING RAIL. FASTEN TO NAILER THROUGH SLOTS 12" O.C. WITH PROVIDED FASTENERS. FIELD CUT AS NEEDED. LOCATE 6" SPRING CLIPS AT MITER COVER SPLICE PLATE OR NO FURTHER THAN 12" FROM CORNER. THEN 4'-0" O.C., MAKING SURE THERE WILL BE A SPRING CLIP UNDER EACH FASCIA COVER END.

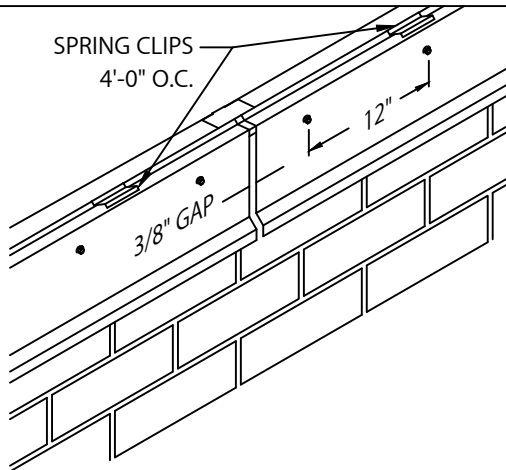
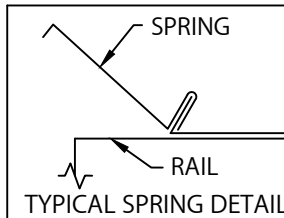

### STEP 6 - BASE RAIL INSTALLATION

INSTALL 12'-0" SECTIONS OF BASE RAIL WITH NON-CURING SEALANT AS SHOWN IN STEP 2. INSTALL BASE RAIL SPLICE PLATE ONTO THE END OF RAIL SECTION TO THE HALFWAY POINT OF THE SPLICE PLATE FLANGE. INSTALL BASE RAIL FROM RIGHT TO LEFT, (AS SEEN FROM ROOF TOP). LEAVE A 3/8" GAP BETWEEN RAIL SECTIONS. FASTEN RAIL TO NAILER THROUGH SLOTS 12" O.C. WITH PROVIDED FASTENERS. FIELD CUT BASE RAIL SECTIONS AS NEEDED.

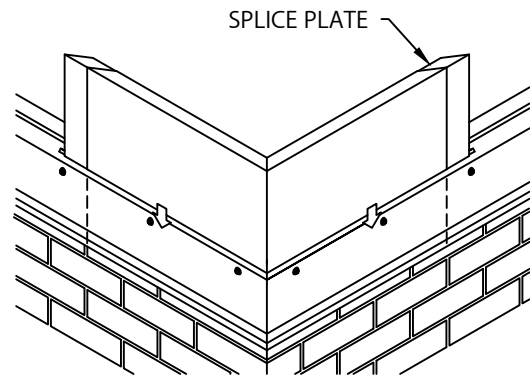

### STEP 7 - MITERS

PLACE SPLICE PLATE INTO EACH END OF MITER COVER. SIMPLY POSITION THE COVER ATOP RAIL AND WITH PALM OF HAND APPLY SLIGHT PRESSURE DOWNWARD UNTIL ENGAGED TO BASE RAIL.



1 CAMPUS DRIVE, PARSIPPANY, NJ 07054 USA  
973-628-3000  
WWW.GAF.COM

DATE: 03/31/22  
DRN BY: MLM  
CKD BY: MM

SHT.# 2 OF 4  
DWG# 25110-38071

A



# M-WELD ONE EDGE FASCIA

BUILT-UP OR MODIFIED VERSION

## SPLICE PLATE VERSION INSTALLATION INSTRUCTIONS

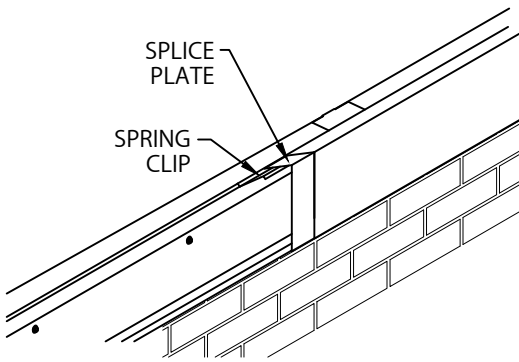

### STEP 8 - FASCIA COVER

REMOVE THE PROTECTIVE FILM FROM FASCIA COVERS. POSITION 12'-0" FASCIA COVERS ON TOP OF BASE RAIL. FASCIA COVERS SHALL BE INSTALLED FROM LEFT TO RIGHT AS SEEN FROM ROOFTOP. PLACE SPLICE PLATE IN RIGHT END OF COVER. SNAP RIGHT COVER ONTO BASE RAIL BY APPLYING DOWNWARD PRESSURE WITH PALM OF HAND UNTIL THE FASCIA COVER IS FULLY ANGAGED ALONG ENTIRE LENGTH. FIELD CUT COVERS AS REQUIRED WITH FINE TOOTH HACKSAW.

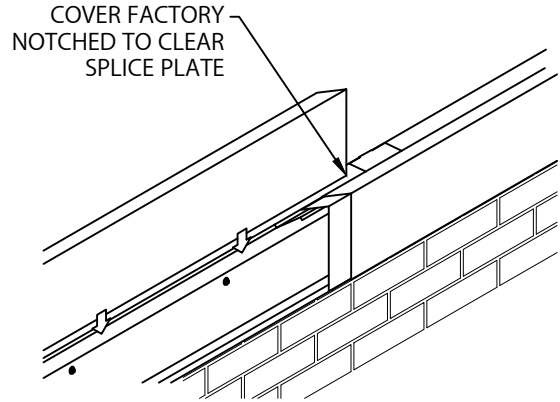

### STEP 9 - FASCIA COVER

POSITION PRE-NOTCHED COVER AND SNAP ONTO BASE RAIL BYPRESSING DOWN WITH THE PALM OF YOUR HAND UNTIL THE COVER IS FULLY ENGAGED ALONG THE ENTIRE LENGTH. ALLOW A 3/8" GAP BETWEEN COVER SECTIONS. FIELD CUT WHERE NECESSARY USING A FINE TOOTH HACKSAW.

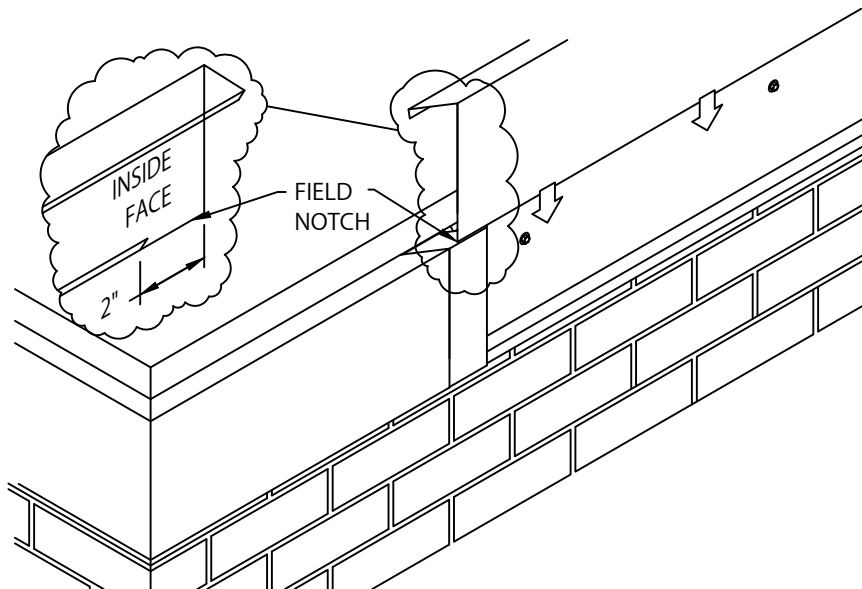

### STEP 10 - FASCIA COVER

AT MITER, FIELD NOTCH RIGHT SIDE OF COVER AS SHOWN. SNAP ONTO BASE RAIL BY PRESSING DOWN WITH THE PALM OF YOUR HAND UNTIL THE COVER IS FULLY ENGAGED ALONG THE ENTIRE LENGTH. ALLOW 3/8" BETWEEN COVER SECTIONS. FIELD CUT WHERE NECESSARY USING THE FINE TOOTH HACKSAW.



1 CAMPUS DRIVE, PARSIPPANY, NJ 07054 USA  
973-628-3000  
WWW.GAF.COM

DATE: 03/31/22  
DRN BY: MLM  
CKD BY: MM

SHT.# 3 OF 4  
DWG# 25110-38071

A



# M-WELD ONE EDGE FASCIA

BUILT-UP OR MODIFIED VERSION

SPLICE PLATE VERSION INSTALLATION INSTRUCTIONS

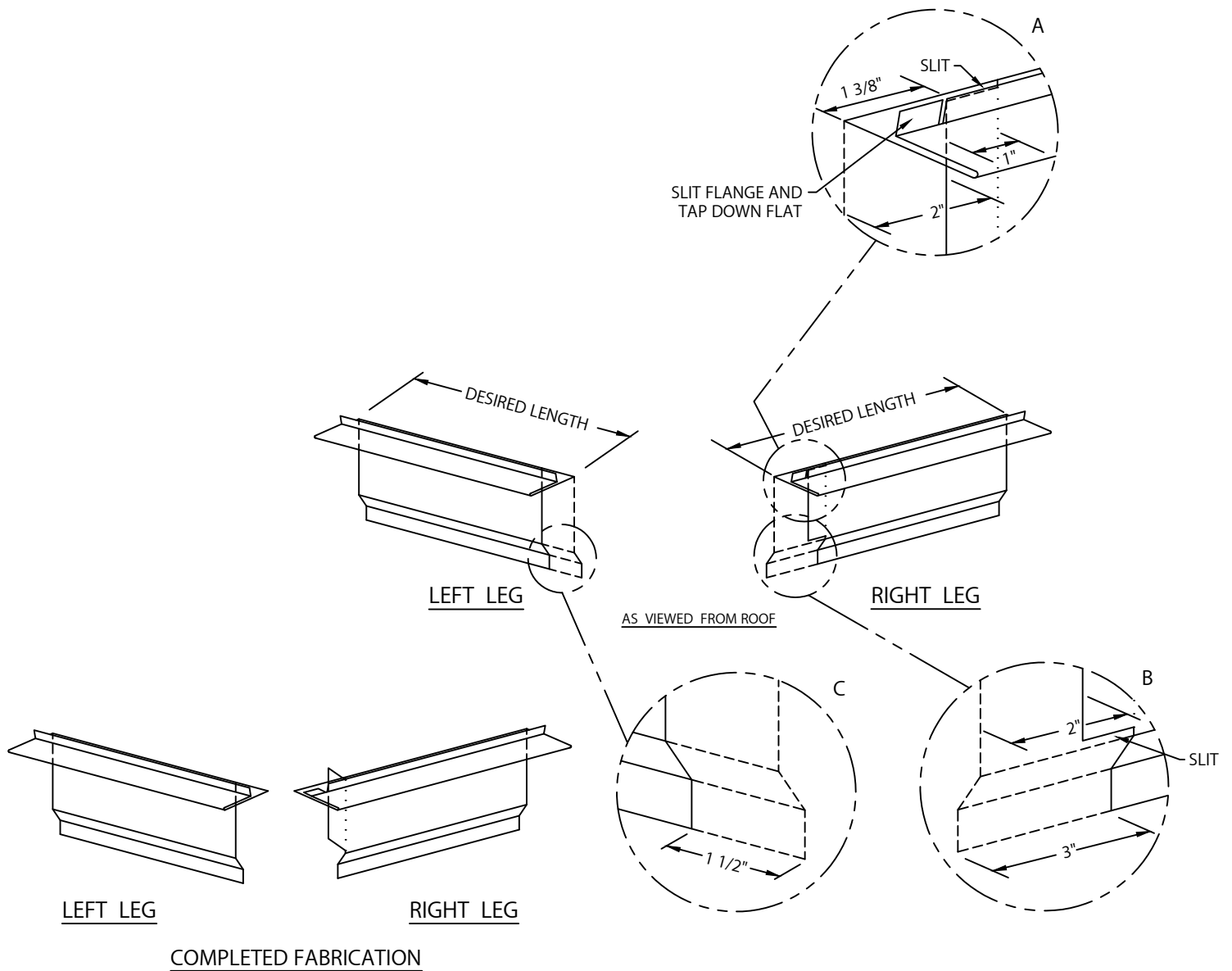

## STEP 11 - INSIDE MITER RAIL FABRICATION (CUT RAIL TO DESIRED LENGTH)

FOR RIGHT LEG-SEE DETAIL A: ON THE TOP FLANGE CUT SLIT  $1\frac{3}{8}$ " FROM THE END AND TAP DOWN FLAT. TRIM BACK THE FRONT FACE  $2$ " AND SLIT FACE  $1$ " AS SHOWN.

DETAIL B: ON THE BOTTOM FLANGE TRIM BACK  $3$ ". SLIT FACE  $1$ " CREATING A  $1$ " TAB. BEND THE TAB OUTWARDS  $90^\circ$ .

FOR LEFT LEG- DETAIL C: TRIM ENTIRE FACE AND BOTTOM FLANGE BACK  $1\frac{1}{2}$ " AS SHOWN.



1 CAMPUS DRIVE, PARSIPPANY, NJ 07054 USA  
973-628-3000  
WWW.GAF.COM

DATE: 03/31/22  
DRN BY: MLM  
CKD BY: MM

SHT.# 4 OF 4  
DWG# 25110-38071

A