

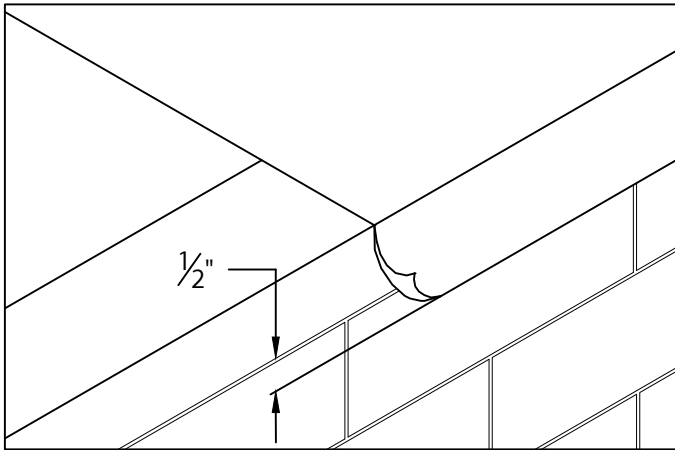

EVERGUARD PRO DRIP EDGE

INSTALLATION INSTRUCTIONS



1. ROOF MEMBRANE

POSITION MEMBRANE OVER THE ROOF EDGE AND DOWN OUTSIDE FACE OF WALL, COVERING TREATED WOOD NAILER(S) COMPLETELY. ALLOW 1/2" EXCESS MEMBRANE.

IMPORTANT! OUTSIDE EDGE OF TREATED WOOD NAILER(S) MIN. 2 x 4) SHALL BE ALIGNED FLUSH WITH OR EXTEND SLIGHTLY PAST OUTERMOST EDGE OF WALL.

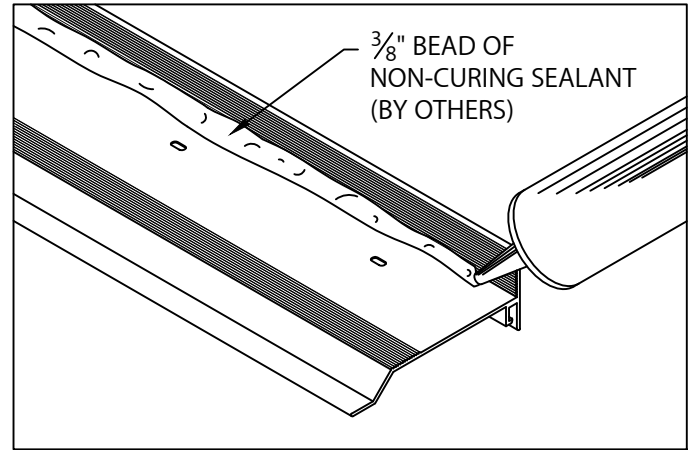

2. ANCHOR BAR

LAY MITERS ON DECK WITH OUTSIDE FACE DOWN. BE SURE ALUMINUM ANCHOR BAR IS CLEAN AND FREE OF DIRT OR DUST. APPLY A HEAVY 3/8" BEAD OF NON-CURING SEALANT (BY OTHERS) TO THE RIGHT ANGLE INTERSECTION OF THE DECK FLANGE AS SHOWN. APPLICATION OF SEALANT IS REQUIRED ALONG THE FULL LENGTH OF EACH MITER ANCHOR BAR.

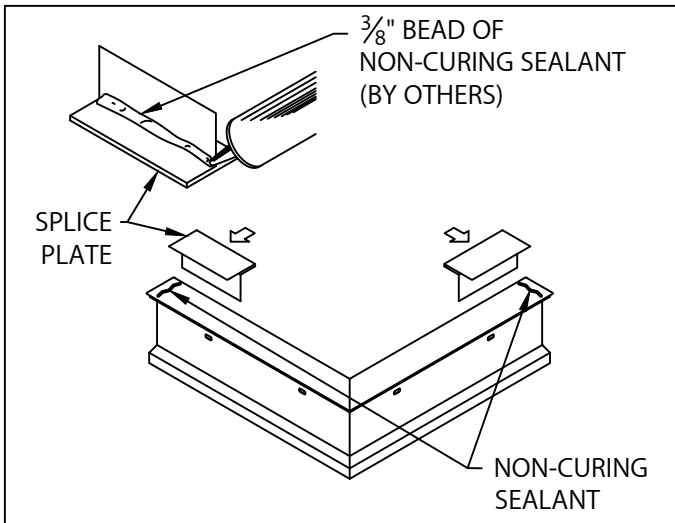

3. ANCHOR BAR MITER SPLICE PLATES

APPLY A 3/8" BEAD OF NON-CURING SEALANT (BY OTHERS) TO THE RIGHT ANGLE INTERSECTION OF THE DECK FLANGE AND TO EACH END OF ANCHOR BAR MITER. SLIDE 3 1/2" WIDE SPLICE PLATE HALFWAY ONTO EACH END OF MITER AS SHOWN.

CAUTION! INSTALLERS SHALL WEAR PROTECTIVE EYE WEAR TO PREVENT INJURY. DO NOT OVERDRIVE FASTENERS, AS STRIPPING CAN OCCUR AT HIGH DRIVER TORQUE. RECOMMENDED DRIVING TOOL: 600 - 800 RPM ELECTRIC DRILL TO PREVENT DRIVING AND STRIPOUT. DO NOT USE IMPACT TYPE TOOL.

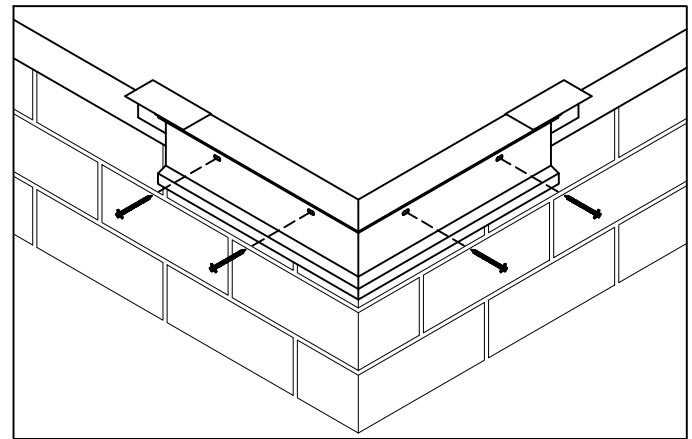

4. ANCHOR BAR MITER

FOLD ROOFING MEMBRANE AT CORNERS. INSTALL MITERS USING FASTENERS AND DRIVER BIT PROVIDED BY MANUFACTURER.



1 CAMPUS DRIVE, PARSIPPANY, NJ 07054 USA
973-628-3000
WWW.GAF.COM

DATE: 03/07/22
DRN BY: MLM
CKD BY: MM

SHT.# 1 OF 3
DWG# 25110-37959

A

DIAGONAL SLOT ANCHOR BAR INSTALLATION

NOTE: IF THE SLOTS ON THE ANCHOR BAR ARE ALL HORIZONTAL, NOT DIAGONAL, FASTEN IN THE CENTER OF THE SLOT

PLACE FASTENER AT TOP OF SLOT FOR SINGLE NAILER INSTALLATION

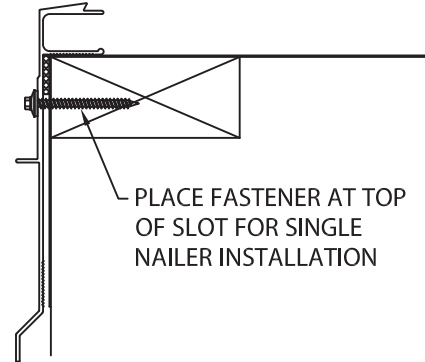

PLACE FASTENER AT BOTTOM OF SLOT IF 1/2" COVER BOARD IS USED

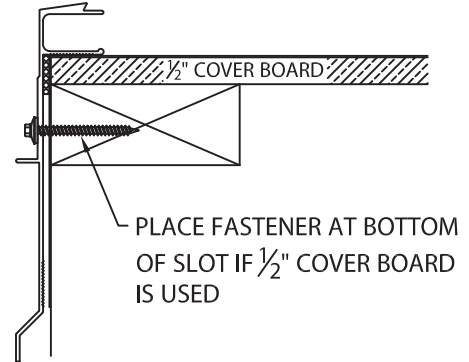

PLACE FASTENER AT BOTTOM OF SLOT IF FASTENING INTO MASONRY

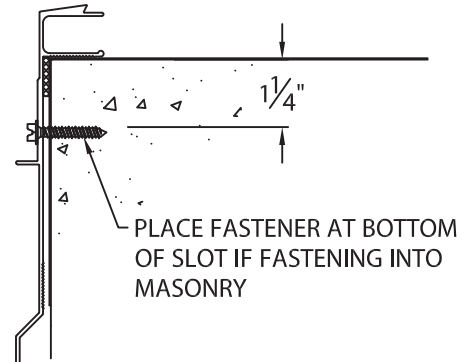

PLACE FASTENER AT BOTTOM OF SLOT IF FASTENING INTO ELIMINAILER-T

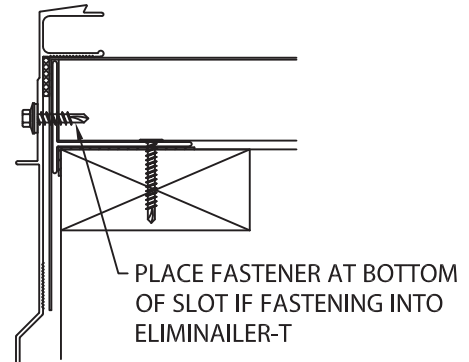



EVERGUARD PRO DRIP EDGE

INSTALLATION INSTRUCTIONS

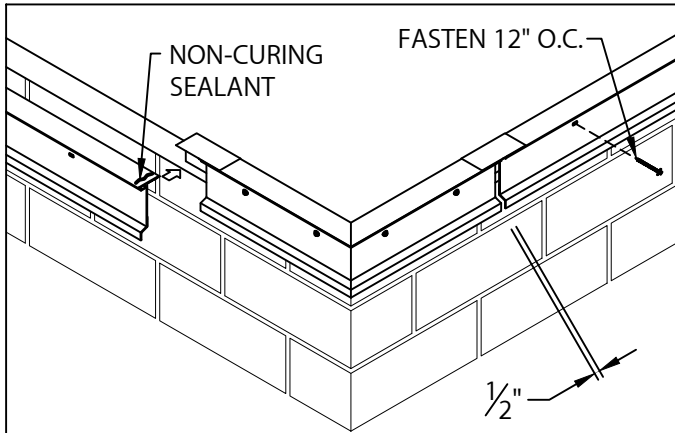

5. ANCHOR BAR

APPLY 12'-0" SECTIONS OF ANCHOR BAR WITH NON-CURING SEALANT AS SHOWN IN STEP 2. ALSO APPLY SEALANT TO ENDS OF ANCHOR BAR AS SHOWN. SLIDE ANCHOR BAR INTO 3½" WIDE SPLICE PLATE. ALLOW ½" SPACE BETWEEN ANCHOR BARS. FASTEN ANCHOR BAR USING PROVIDED FASTENERS. CONTINUE INSTALLING 12'-0" LENGTHS OF ANCHOR BAR AND 3½" SPLICE PLATES. FIELD CUT SECTIONS AS NECESSARY.

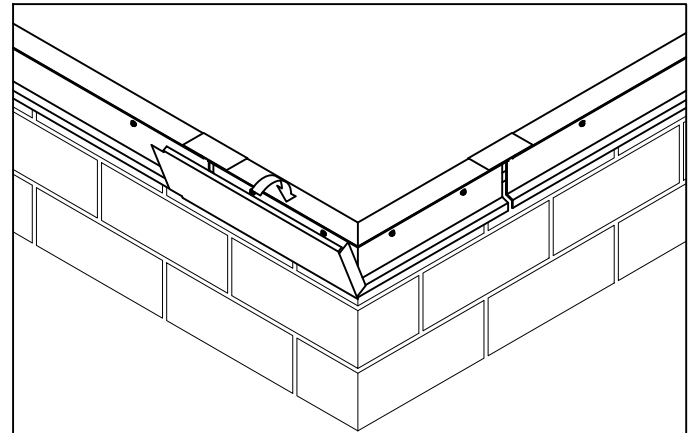

6. FASCIA MITER COVERS

INSTALL TWO PIECE SNAP ON FASCIA MITER COVER BY HOOKING FASCIA MITER COVER WITH 90° TAB TO BOTTOM OF ANCHOR BAR AND ROTATING INTO PLACE.

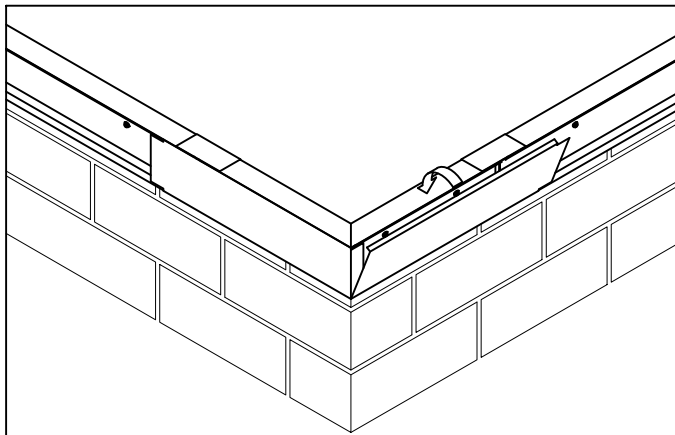

7. FASCIA MITER COVERS

INSTALL OTHER HALF OF MITER COVER (WITHOUT 90° TAB) AS SHOWN IN STEP 6.

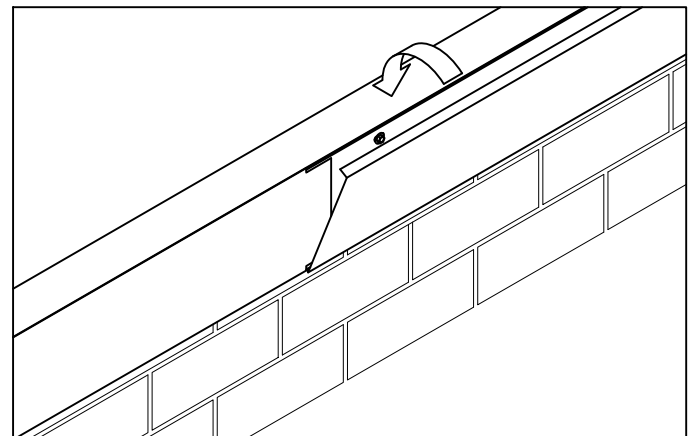

8. FASCIA COVERS

POSITION 12'-0" FASCIA COVERS ON TOP OF ANCHOR BAR AND OVERLAP PRECEDING COVER APPROXIMATELY 1" AT NOTCHES PROVIDED. FASCIA COVERS SHALL BE INSTALLED FROM RIGHT TO LEFT AS SEEN FROM THE ROOFTOP. WITH FASCIA HOOKED TO BOTTOM OF ANCHOR BAR, ROTATE COVER INTO PLACE, APPLYING PRESSURE ALONG ENTIRE COVER UNTIL IT IS FULLY ENGAGED. CONTINUE INSTALLING FASCIA COVERS FIELD CUTTING WHERE NECESSARY USING A FINE TOOTH HACKSAW. IMPORTANT! REMOVE PROTECTIVE FILM IMMEDIATELY.



1 CAMPUS DRIVE, PARSIPPANY, NJ 07054 USA
973-628-3000
WWW.GAF.COM

DATE: 03/07/22
DRN BY: MLM
CKD BY: MM

SHT.# 2 OF 3
DWG# 25110-37959

A



EVERGUARD PRO DRIP EDGE

INSTALLATION INSTRUCTIONS

TYPICAL INSTALLATION

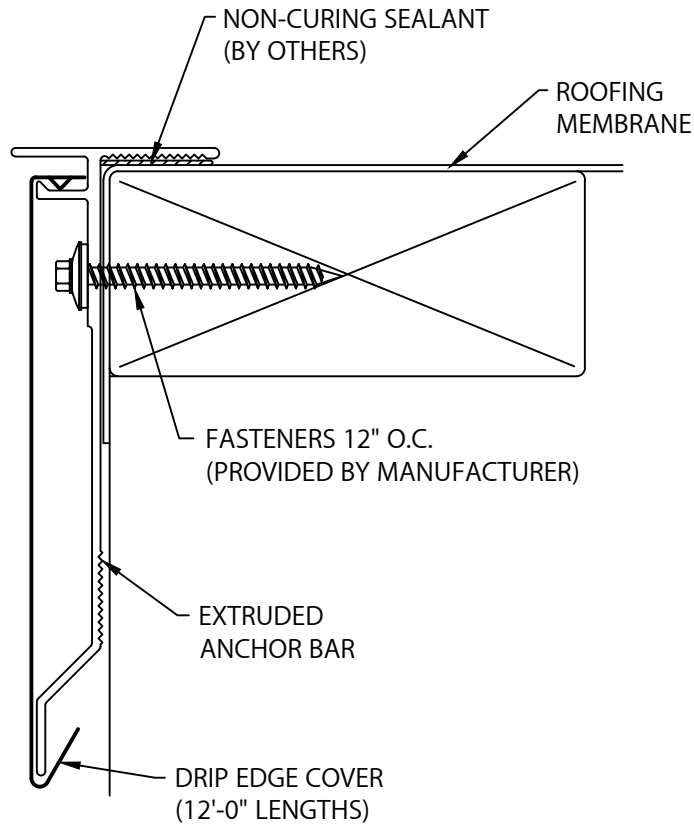

1 CAMPUS DRIVE, PARSIPPANY, NJ 07054 USA
973-628-3000
WWW.GAF.COM

DATE: 03/07/22
DRN BY: MLM
CKD BY: MM

SHT.# 3 OF 3
DWG# 25110-37959

A