

EverGuard® GAF Pro Drip Edge



Standard Version

Description:

EverGuard® Pro Drip Edge combines high performance with an attractive appearance. The extruded aluminum anchor bar can be used to securely terminate single-ply membranes, providing protection superior to any shop-fabricated drip edge. With a variety of unique applications, the EverGuard® Pro Drip Edge is versatile and easy to install.

Features and Benefits:

- Full snap-on design with extruded aluminum bar for easy installation.
- Sizes range from 3" (76.2 mm) – 7.5" (190.5mm) face heights to accommodate multiple nailers and wall requirements.
- Covers can be manufactured in 24 ga. steel and .040" aluminum.
- Express, standard, and premium colors and finishes are available to meet your job requirements

and include a 30-year Kynar 500® finish warranty on coil-coated standard colors. Custom colors are also available.

- A limited ten- (10) year warranty is included for post-painted Kynar®-coated aluminum applications unless otherwise stated. A twenty- (20) year warranty is also available only upon request at the time of order.*

* Restrictions may apply; consult a sales representative for specific information.

Codes/Testing Compliance

- Tested per ANSI/SPRI/FM 4435/ES-1 Standard to comply with the International Building Code
- FM approved for wind uplift protection. Refer to RoofNav.com for actual assemblies.



10 Express Colors¹

Express Colors are available for quick shipping to meet your job requirements.²



For standard and premium colors, please refer to the GAF color chart, available at gaf.com/perimeteredgemetal. Custom colors are also available.

¹ It is difficult to reproduce the color clarity of these products. Before selecting your color, please contact your local GAF territory manager to request a paint chip for accurate color representation.

² Express Colors available in shorter lead times for 24 ga., .040", and .050" only. Standard lead times, which may be longer, apply for 22 ga. and .063".

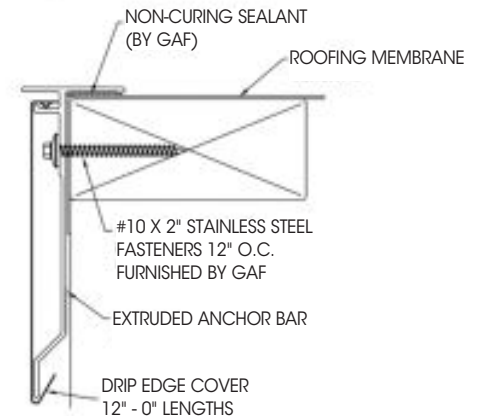

Product Specifications

STANDARD SIZES	3 in. (76.2 mm) 4.5 in. (114.3 mm) 6 in. (177.8 mm) 7.5 in. (190.5 mm)
LENGTH	12 ft. (6.10 m)
MATERIALS	24 ga. steel .040" aluminum
FINISHES	Mill aluminum Pre-finished Kynar 500® (See standard color chart) Premium pre-finished Kynar 500® (See standard color chart) Post-finished Kynar 500® Pre-finished anodized aluminum – clear, bronze, or black Post-finished anodized aluminum Custom post-coated Kynar 500® finishes are available
PRE-PUNCHED HOLES	12 in. (305 mm) o.c.



Visit gaf.com/PerimeterEdgeMetal

We protect what matters most™

